



# Focus on Aerospace, Defence and Security

**Driving success  
by executing our goals**





# Defence and Civil Large Systems

Remo Pertica  
Co-Chief Operating Officer

**Driving success  
by executing our goals**



# World market and trends

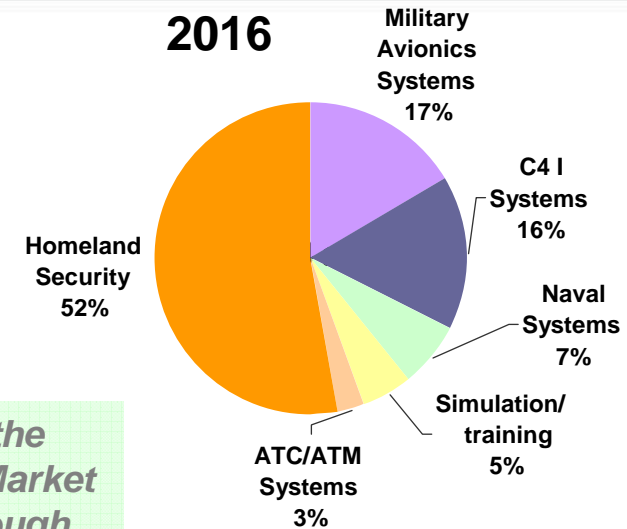
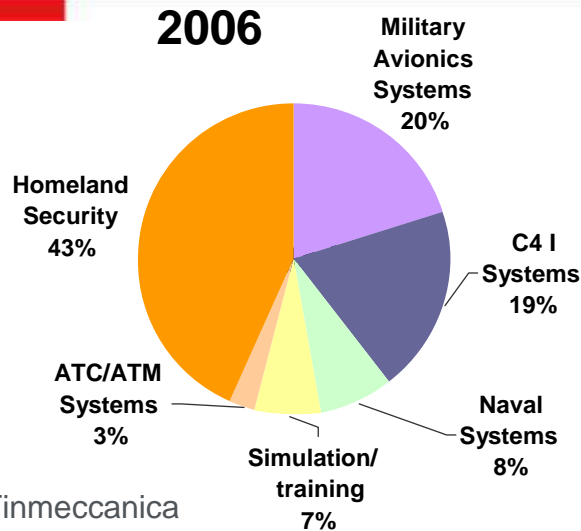

*More than 20 % of the Electronics Defence Market will be procured through Large System acquisition*

source: Finmeccanica

## TREND DRIVERS

- Markets are requiring solutions to **Capabilities**. Capability solutions require high system integration skills.
- The more advanced operational concept is related to net centric operation.
- **Network Enabled Capability** requires Large Systems providers to deliver solutions for new customer requirements.
- **Homeland Protection** which represents more than 50% of the entire defence electronic market is consolidating its structure, rewarding those companies characterised by architectural design and Large System Integration capabilities.
- **Battlefield Digitalisation** has witnessed the same processes in different countries with the issuing of large programmes requiring interoperability, security and ability to satisfy large systems integration to allow information superiority requirements and operational awareness requirements.

# Large systems

*A large system is a network-based structure in which the single components have different specific configurations and tasks but, when used and integrated together, activate new important functions of a superior level.*

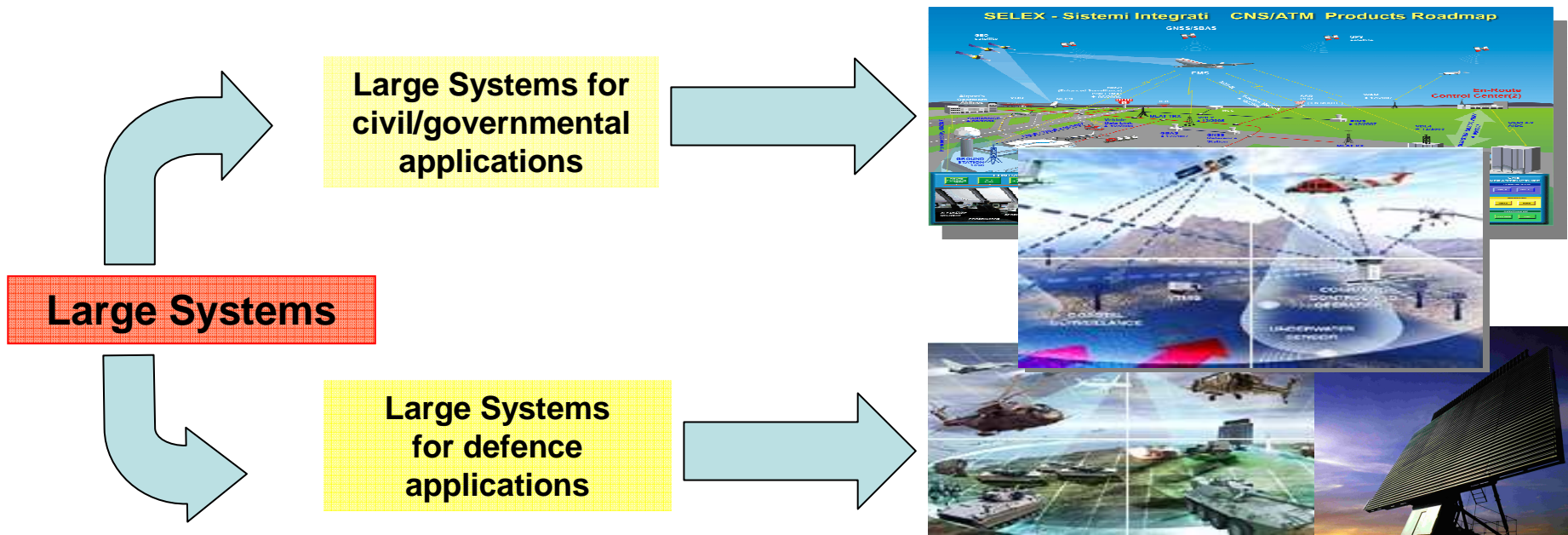

*Finmeccanica is continuously improving its know-how for the integration of complex system, and is recognised as a market leader.*

*Furthermore, its wide differentiated portfolio and segmentation represent an exceptional competitive advantage to manage complex programmes because provided solutions can be properly tailored and customised.*

# Large system for defence: Forza NEC



- New operational scenarios require more complex equipment from the technological standpoint to ensure interoperability, deployability, high mobility and high survivability.
- All the Countries currently involved in the out of area PSO (Peace Support Operation) are transforming their structure architecture in order to be compliant with the new Net Centric doctrine.
- Within this framework, the Italian Army is launching a transformational project, called Forza NEC, that applies the new concepts of Digitalisation and Network Centricity to the battlefield.
- Forza NEC is a spiral project, envisaging the realisation of three digitalised medium-sized brigades by 2015, which will be consistent with the plan to deliver and integrate Land Forces by 2025.
- Finmeccanica, through its subsidiary Selex SI, has been selected as Project Leader. First development of this project will start in 2008. All the other Finmeccanica subsidiaries will contribute assets, products and capability.
- Similar programmes in the world: FCS in USA, FRES in UK, SCORPION in France.

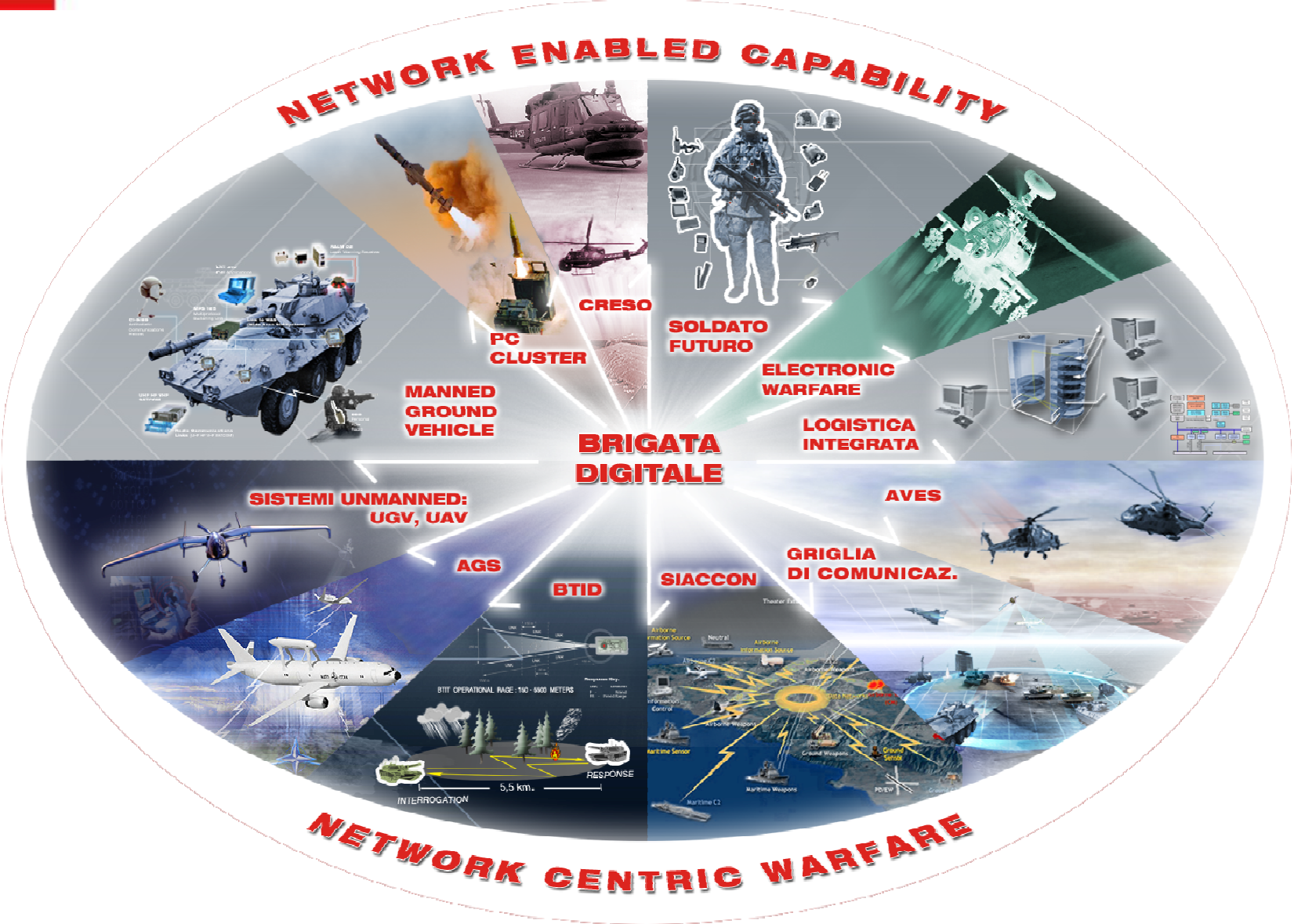

# Large systems for civil: Homeland protection



*Ability to tailor systems in accordance with customer's required solutions*

**CIVIL EMERGENCIES & MAJOR EVENTS MANAGEMENT**

**PIPELINE CONTROL**

**OIL&GAS INFRASTRUCTURES CONTROL**

**VTS & MARITIME BORDER CONTROL**

**LAND BORDER CONTROL**

**TERRITORY CONTROL**

Italy

Italy, UK, China

Libya

Italy, Poland, Yemen

Libya, Algeria, Turkey

Algeria, Saudi Arabia, Malaysia, Oman, Turkey, Italy

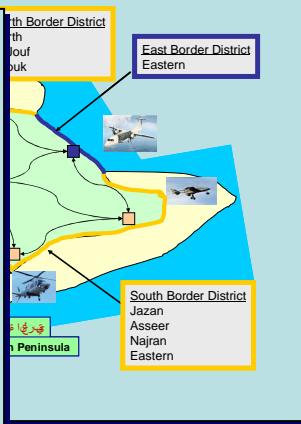
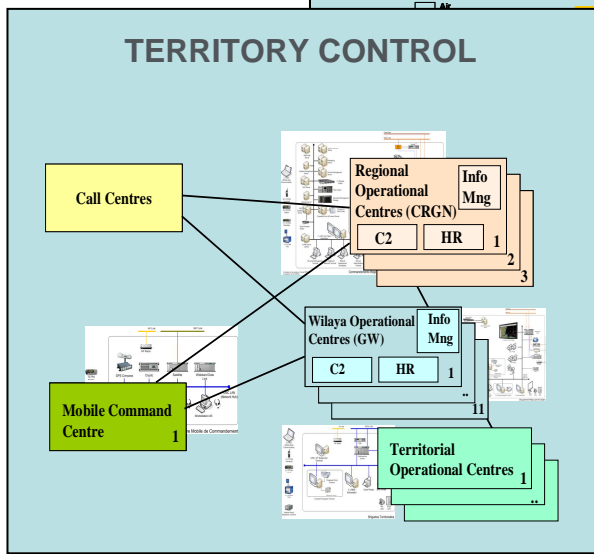

# Large systems for civil: Homeland protection



- Finmeccanica has developed an internal capability to offer complete and customised solutions for this Market.
- Homeland Security is a large market (Total World Market around €45 bn) with a CAGR of approximately 8% between 2006-2016.

		<i>Integrated Solutions of lower complexity</i>	<i>Integrated Solutions of higher complexity</i>
✓ Border Control	<b>Blue border</b>	Malaysia Coastal Security €75 m Italy national VTS €60 m Turkey, Tunisia, Greece, Latvia VTS €152 m	
	<b>Green border</b>	Algeria SEF (>€600 m) Algeria RUNITEL II (€240 m) Qatar Border Control (€245 m)	Saudi Arabia Border Control (> €5 bn)
✓ Country Control		Libya overall Homeland Security (€670 m)	Turkey IBM (> €3 bn)
Total Value		> €2 bn	> €8 bn



# Cutting edge platforms, products and technologies for Large Systems



- Finmeccanica is also leveraging its integration capability through its platforms competencies (naval, air and terrestrial applications).
- Radar and Integrated Systems, Communications, Sensors and Airborne Systems and the platform manufacturers, Aeronautics, Helicopters and Naval Turrets, are providing state of art solutions all over the world.

## AIR



## NAVAL



## GROUND

